

Trout Habitat Preservation Project (THPP)

A. Project Location

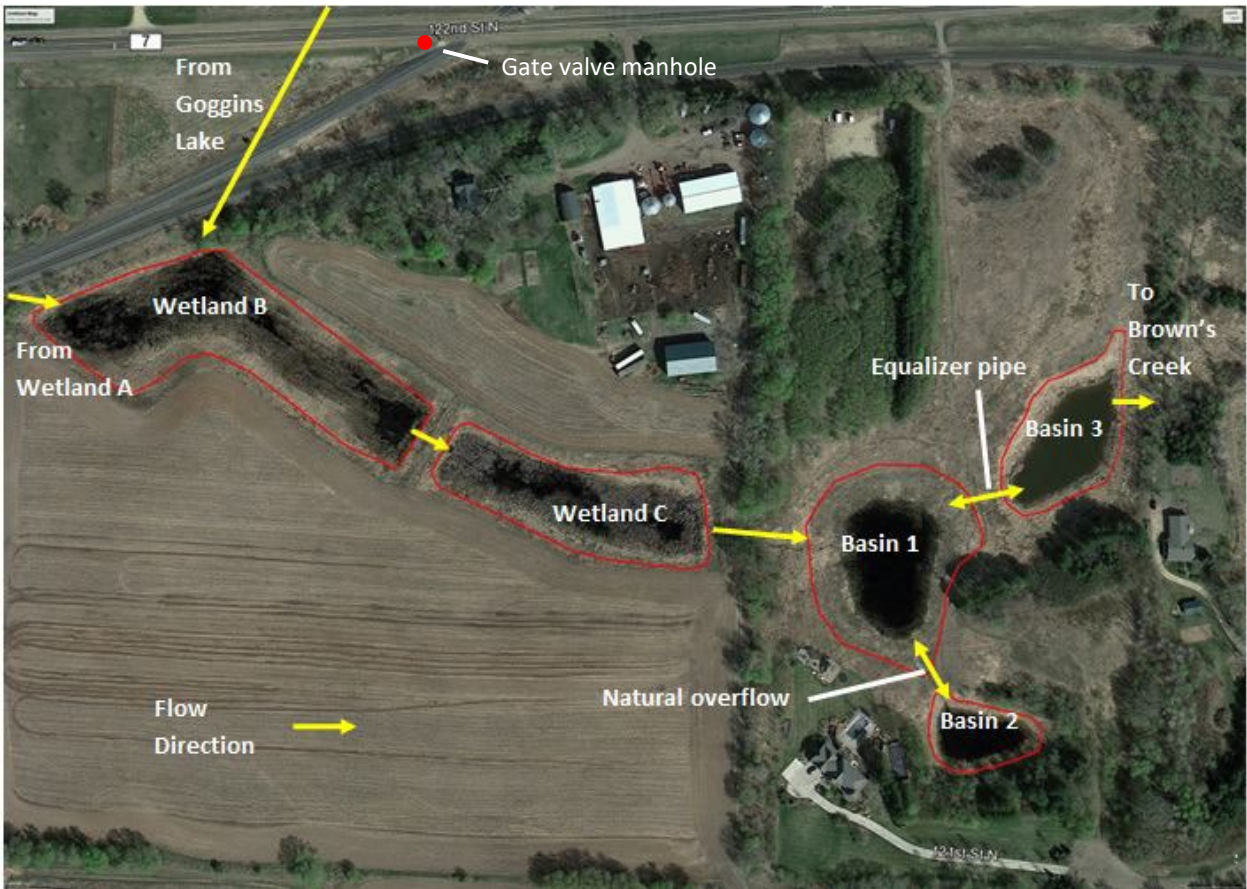

Figure 1. Location map for the Trout Habitat Preservation Project

Project Location	Immediate Waterbodies Impacted	BMP Performance
		Estimated Thermal Load Reduction
The Trout Habitat Preservation Project (THPP) is located south of 122 nd Street North and west of Manning Trail North in the City of Grant, MN (see Figure 1 for a Location Map).	Brown's Creek	The Trout Habitat Preservation Project mitigates thermal load impacts resulting from the overflow of Goggins Lake into Brown's Creek

B. Description of Facility

I. General Site Description

The Trout Habitat Preservation Project utilizes wetland creation and infiltration to store and infiltrate direct drainage and overflow from the Goggins/School Section Lakes system. The goal of the project was to alleviate flooding in an otherwise landlocked system while mitigating hydrologic and thermal impacts to Brown’s Creek. The THPP is a dynamic system which requires ongoing maintenance activities to ensure its success into the future.

The THPP was constructed in the winter of 1999 to stabilize water levels within the Goggins/School Section Lakes system while protecting brown trout within Brown’s Creek. A series of wetlands and infiltration basins were constructed and enhanced to store and infiltrate water, thereby reducing the amount of water discharged to the headwaters of Brown’s Creek. Following construction, routine monitoring has occurred to track the long-term performance of the THPP system. Monitoring from 2004-2006 indicated a reduction in infiltration within the system. As a result, an infiltration trench and equalizer pipe were installed in Basin 1 in 2007. These modifications improved the infiltration capacity of Basin 1 and allowed for additional water from Basin 3 to be infiltrated in Basin 1. Ongoing monitoring occurs on a three-year basis to track the long-term performance of the system and infiltration trench.

The THPP site occurs entirely on private lands with an easement held by the Brown’s Creek Watershed District (BCWD) to maintain the facility. As of 2018, the land around Wetland A is owned by Sabina Holdings LLC, Keith Dewolf owns the land around Wetland B and Wetland C, and Scott and Angelene Mellick own the land around basins 1, 2 & 3. In general, the BCWD easement occurs around the grassy buffers of each wetland and basin.

Partners	Project Purpose	Drainage Size	Project Completed	Maintenance Requirement
BCWD, MNDNR, Washington County, and landowner of Basin 1/prairie area	Stabilize water levels on Goggins/School Section chain-of-lakes, promote groundwater recharge to Brown’s Creek and reduce thermal loads to the headwaters	4,124 acres	2000	Entire life of structure
Note 1: BCWD is responsible for maintenance. BCWD holds easements over the project area.				
Costs				
Total Project Cost: \$864,071 (including design and construction)				
<ul style="list-style-type: none"> Leveraged Legislative-Citizen Commission on Natural Resources (LCCNR) Funding Leveraged DNR: \$18,000 Local BCWD Tax Levy Funding 				

II. Parts Inventory

Item #	MN/DOT SPEC. NO.	Item	Quantity	
1	NA	GOGGINS LAKE 30"RCP OUTLET	1	EA
2	NA	MH WITH GATE VALVE AT COUNTY ROAD 7 @ RR CROSSING	1	EA
3	NA	WETLAND A – 36"RCP CROSSING UNDER RR TRACKS	600	LF
4	NA	WETLAND B - DROP OUTLET W/TRASH RACK AND 24" ARCH RCP	1	EA
5	NA	WETLAND C – TWIN 24" ARCH RCP		LF
6	NA	BASIN 1 – DROP OUTLET W TRASH RACK AND 24" ARCH RCP	1	EA
7	NA	BASIN 1 – 10" HDPE EQUALIZER PIPE		LF
8	NA	INFILTRATION TRENCH		
9	NA	BASIN 2 – DROP OUTLET WITH TRASH RACK AND 24" ARCH RCP		

III. Stormwater Management Facilities

The THPP operates as follows: discharge from the Goggins/School Section Lakes system enters Wetland B in the northwest corner of the site. Drainage from Wetland A enters Wetland B at the southwest corner of the site. Wetland B discharges to Wetland C through a drop outlet structure with a 24" diameter round concrete pipe. Wetland C discharges into Basin 1 through twin arched round concrete pipes. Basin 2 flows into Basin 1 via natural overland flow at the 966 foot elevation. Water in Basin 1 infiltrates through the ground and infiltration trench. During high water events in the THPP system, water in Basin 1 flows through a drop outlet structure with a 24" round concrete pipe into Basin 3 before discharging through another drop outlet structure with a 24" round concrete pipe into the headwaters of Brown's Creek. Table 1 summarizes the structures of the THPP system.

IV. Accessibility and Gate Valve Operation

The dirt trail located immediately south of 122nd Street and approximately 0.15 miles east of the railroad crossing on County Road 7 is used to gain access to the THPP facility. The Goggins Lake gate valve manhole is located at the southern edge of the asphalt shoulder on County Road 7/ 122nd Street (Figure 2). The coordinates of the manhole in Latitude and Longitude are as follows: 45° 07' 38.81" N, 92° 52' 20.13" W. The gate valve controls the water elevation of Goggins Lake when the lake elevation is above 970 feet. Opening the Goggins Lake gate valve is necessary to draw down Goggins Lake during high water events to prevent flooding of property upstream. The gate valve is operated by turning the 2" square nut counterclockwise to open or clockwise to close (Figure 3). The gate valve is currently in the open position. For safety, EOR has a gate valve key that can be used to turn the nut while standing on top of the manhole. The 2" square nut is located approximately 10 feet below the ground surface; therefore, the gate valve key is necessary to prevent entering the manhole (confined space) to operate the valve.



Figure 2. Goggins Lake gate valve manhole location on County Road 7 / 122nd Street



Figure 3. Goggins Lake gate valve nut (2" square nut highlighted in yellow). Turn counterclockwise to open the valve.

V. Start-Up and Operating Procedures

a. Process Description

Not Applicable for this project

b. Controls

Not Applicable for this project

c. Start – Up Procedures

Not Applicable for this project

d. Normal Operating Procedures

Since 2003 the gate valve on the Goggins Lake outlet has remained open to prevent adverse high water levels and flooding of adjacent properties. Since this time, the lake elevation of Goggins Lake has not reached the outlet elevation so there has been no discharge to the THPP system from the lake. Each spring, the THPP system receives discharge as a result of snowmelt from the contributing drainage area. Basins 1 and 3 are monitored daily for stage and temperature to evaluate system performance and if discharge occurs to the headwaters of Brown’s Creek. If lake levels on Goggins Lake are above the outlet elevation and there is discharge through the THPP system that is too warm (above 68 degrees F) or too cold (below 32 degrees F) for downstream trout populations, the gate valve must be closed.

The following table summarizes the normal operating procedures for the THPP.

Task	J	F	M	A	M	J	J	A	S	O	N	D
Install monitoring equipment following spring snowmelt or rainfall events		X	X	X	X	X	X	X	X	X		
Perform routine inspections				X						X		X
Annual maintenance activities												
• Culvert cleaning (as needed)									X	X		
• Prairie Burn			X	X	X					X		
• Invasive Species Management	X	X									X	X
Remove monitoring equipment										X		

The following personnel can be contacted for normal operating procedure questions.

Contact Personnel		Contact Number	Organization
Primary	Karen Kill, Administrator	651-330-8220 x26	BCWD

Secondary	John Sarafolean, Water Resources Specialist	651-470-5421	Emmons & Olivier Resources, Inc.
------------------	---	--------------	-------------------------------------

e. Common Operating Problems

Inspect culverts to make sure they aren't collecting sediment which would affect flow rates through the THPP system and operating the gate valve to ensure proper function.

C. Maintenance and Inspection Requirements

I. Planning Maintenance and Inspections

Inspections should be made two times per year in the spring and the fall.

a. Inspection Procedures

Item	Item Location	Parameter Measured	Inspection Frequency
Culverts, drop structures, trash racks and Goggins Lake outlet gate valve	See Parts Inventory Table above	Debris on grate cover, sediment buildup in culverts	Bi-Annual inspection
Wetlands A, B & C and Open Channel	East of railroad tracks	Inspection of sediment accumulation within the basins	Bi-Annual inspection
Infiltration Basin (Basins 1 and 2)	See Figure 1 above	Inspection of sediment accumulation and efficiency assessment	Bi-Annual inspection
Native Prairie	Buffer of each wetland and basin within the project boundary	Inspection for spread of terrestrial invasive species	Annual inspection

Inspections should include documentation (*Outlined in Section E, Record of Annual Inspection and Maintenance Program*) and measurements of the following BMP components:

1. *Document the presence of sediment, leaf litter, or other debris on the trash racks.*
2. *Visually inspect the culverts and Goggins outlet for the accumulation of sediment.*
3. *Visually inspect the wetlands, infiltration basins and trench surface (Basin 1) for erosion and sediment control issues and the accumulation of sediment in the bottom of the basins.*
4. *Visually inspect the surrounding prairie areas for the presence of terrestrial invasive species.*

b. Maintenance procedures

Item	Corrective Action	Maintained by	Maintenance Frequency	Estimated Annual Cost (Based on 2017 Estimate)
------	-------------------	---------------	-----------------------	---

Minor debris and sediment removal from trash racks and culverts	Clear with hand tools or Vac Pump	BCWD or Contracted Party	As determined by inspections	\$2,500
Removal of sediment from wetlands and infiltration basins	Sediment removal, native plantings and site restoration	Contracted Party	Once every 20 years	~ \$20,000
Prescribed burns	Burning Wetlands B and C, Basins 1, 2 & 3, and adjacent prairie areas (~ 13.5 acres)	Contracted Party	Once every 5 years	\$5,100
Miscellaneous maintenance activities	Mowing, revegetation, tillage, cut stump treatment of invasives, (Natural Shores Technology)	BCWD or Contracted Party	As determined by inspections	\$4,500
Monitoring infiltration basins	NA	Contracted Party	Every three years	\$3,500
Conduct as-built survey of structures to assess settling	DGPS or level loop of all structures	BCWD	Every 10-15 years	\$2,500
Annual Inspections	NA	BCWD	Twice per year	\$1,500
Anticipated Total 2026 Maintenance Cost:				\$8,500 + TBD

1. Structural Operation and Maintenance

In general, this will involve the annual inspection of culverts, drop structures, trash racks, and the Goggins Lake outlet gate valve as listed in Table 1 above. Minor amounts of debris may need to be removed from trash racks and outlet structures to maintain proper flow patterns and pipe capacities. If sediment accumulation occurs within the culverts, the sediments should be removed with either shovels or vacuum excavating equipment.

2. Wetland and Open Channel Maintenance

Sediments may need to be removed from the bottom of the wetlands every 20-25 years and minor channel cleaning approximately every 15-20 years. The discharge from the Goggins/School Section Lakes system contains very little suspended sediment so no significant sediment accumulation is expected in the created wetlands other than from local erosion from the surrounding agricultural fields. Maintenance of the vegetated buffers surrounding each wetland and basin is critical to limit sediment migration into the THPP system.

3. Infiltration Basin Maintenance

This will include annual basin inspection and efficiency assessment and partial revegetation, tillage, and scarification of the bottom of the basin as needed (approximately every 20 years). Other practices may include mowing and monitoring of the infiltration trench.

4. *Invasive Species Management*

Prescribed burns are conducted every 3-5 years to maintain the native prairie vegetation throughout the THPP facility and to reduce the spread of invasive species. The prescribed burns are conducted in early spring when weed species are beginning to develop. Box elder tree removal and subsequent cut stump treatment may be required when prescribed burning is unable to effectively control the spread of the trees within the prairie area.

II. Corrective Actions and Modifications

Corrective actions and modifications are based on the performance of the system as a whole: capacity to retain and infiltrate overflow from the Goggins/School Section chain-of-lakes without outletting cold or warm runoff to the headwaters of Brown's Creek.

III. In-house Verses Contracted Labor

To be determined on an as-needed basis.

I. Sampling and Performance Monitoring

a. Sampling and Analysis

BCWD is responsible for coordination of routine sampling. Water quality sampling is to be added to normal inspection procedure.

b. Performance monitoring

BCWD is responsible for recording and interpreting results of samples. If a sample is believed to be of contaminant nature, further lab testing may be required. Consult the BCWD Administrator if samples appear to be of contaminant nature.

D. Maintenance Responsibilities and Agreements

The BCWD has sole responsibility for the maintenance and monitoring of the wetlands, infiltration basins and buffer areas within the THPP project site. The BCWD will conduct routine maintenance activities to ensure performance of the system and enhance the wildlife and habitat benefits of the project.

I. Manufacturer's Recommendations

Not Applicable for this project

II. Safety

Before entering a retention or detention system, ensure all OSHA and local safety regulations are being followed. Only personnel with appropriate confined space permits and personal protective equipment should be allowed to enter the system. It is highly recommended that two field staff operate the gate valve which can be difficult to turn and can cause injury.

E. Records and Reporting

Records and reporting should be submitted to and maintained by BCWD. The following information should be recorded during all inspection visits: sediment depth in culverts and outlet structures, note any sediment or debris within the basins and any vegetation maintenance needs.

Record of Annual Inspection and Maintenance Program:

Inspector Information				
Visit Number:				
Name				
Date:				
Identifier Number	Structure Description	Debris / Sediment	Sediment Depth (in)	Notes
1.	Goggins Lake Outlet and Gate Valve	Y / N		
2.	Wetland A Drop Structure and RR Crossing	Y / N		
	Wetland B Drop Structure	Y / N		
	Wetland C Twin Arch Culverts	Y / N		
3.	Basin 1 Drop Structure and Equalizer Pipe	Y / N		
	Basin 2 Natural Overflow	Y / N		
	Basin 3 Drop Structure	Y / N		
4.	Wetland Basins	Y / N		
5.	Infiltration Basins	Y / N		
6.	Prairie Composition	NA	NA	
Maintenance Description:				
Contractor / Maintenance Crew Information				
Date:				
Name:				
Phone:				
Address:				
Maintenance Description:				

F. Emergency Plan and Operating Procedures

I. Emergency Plan

Issues that would trigger the Emergency Operating Procedure consist of high water conditions within the Goggins/School Section chain-of-lakes system if the outlet valve is closed. Always call 911 in a situation that presents a risk of immediate bodily harm to yourself or the surrounding community.

II. Emergency Operating Procedures

There is the potential for high temperature water to discharge from the THPP facility outside of the normal shut-down periods for the system. There is also potential for high water conditions within the Goggins/School Section Lakes system to occur at times when the outlet valve is closed. The following criteria will be used to determine if it is necessary to depart from the normal operation plan and perform an emergency shutdown or opening of the system.

Water temperatures that have the potential to negatively impact trout have occurred when the ambient air temperatures exceed 90 degrees F. When the air temperature reaches 90 degrees F, water temperatures will be measured at the THPP outlet (Basin 3 drop structure), at County Road 68, at McKusick Road, and at the mouth of Brown's Creek. If any of the temperatures exceed 73 degrees F, the outlet valve will be closed. If the daily high ambient air temperature exceeds 90 degrees F for two consecutive days, the outlet valve will be closed. Under these scenarios, the valve will be reopened after the water temperatures and ambient air temperatures have cooled. Professional judgement on the part of the District and in consultation with the DNR will be necessary in these situations.

To limit the risk of property flooding within the Goggins/School Section Lakes system, water elevations within Goggins Lake will be monitored during shut-down periods (especially from February 15 to March 15). If the lake level exceeds 972.0 feet, the outlet valve will be reopened. All downstream flow and temperature monitoring stations will be monitored daily while the outlet valve is open. Professional judgement on the part of the District and in consultation with the DNR will be necessary in this situation to determine if the results of the monitoring data will necessitate re-closing the outlet valve.

To limit thermal impacts to Brown's Creek and potential flooding in the Goggins/School Section Lakes system, it may be possible to conduct volume control of discharge through the Goggins Lake gate valve such that the THPP facility is inundated to the level just below the elevation of the THPP outlet at Basin 3 (approximate elevation of 968 feet). Following inundation to the Basin 3 outlet elevation, the gate valve should be closed and the THPP facility should be allowed to infiltrate and "dry out" over a two-three week period. The gate valve could then be re-opened and the THPP facility re-flooded as needed to reduce water levels in the Goggins/School Section Lakes system. If sufficient infiltration occurs within the THPP facility, this approach will allow for discharge to be pulsed out of Goggins Lake to maximize the volume of water infiltrated by the THPP facility and limit the amount of water discharged to Brown's Creek. However, if water levels in Goggins Lake exceed the 972 feet, the gate valve must be fully opened.

In the event on an operational emergency, please contact the following personnel for further assistance.

Contact Personnel		Contact Number	Organization
Primary	Karen Kill, Administrator	651-330-8220 x26	BCWD
Secondary	John Sarafolean, Water Resources Specialist	651-470-5421	Emmons & Olivier Resources, Inc.

G. Appendices

I. Record Drawing

II. Agreements

- a. Access Agreement
- b. Easement Descriptions

Browns Creek Watershed District Trout Habitat Preservation Project

LOCATION MAP

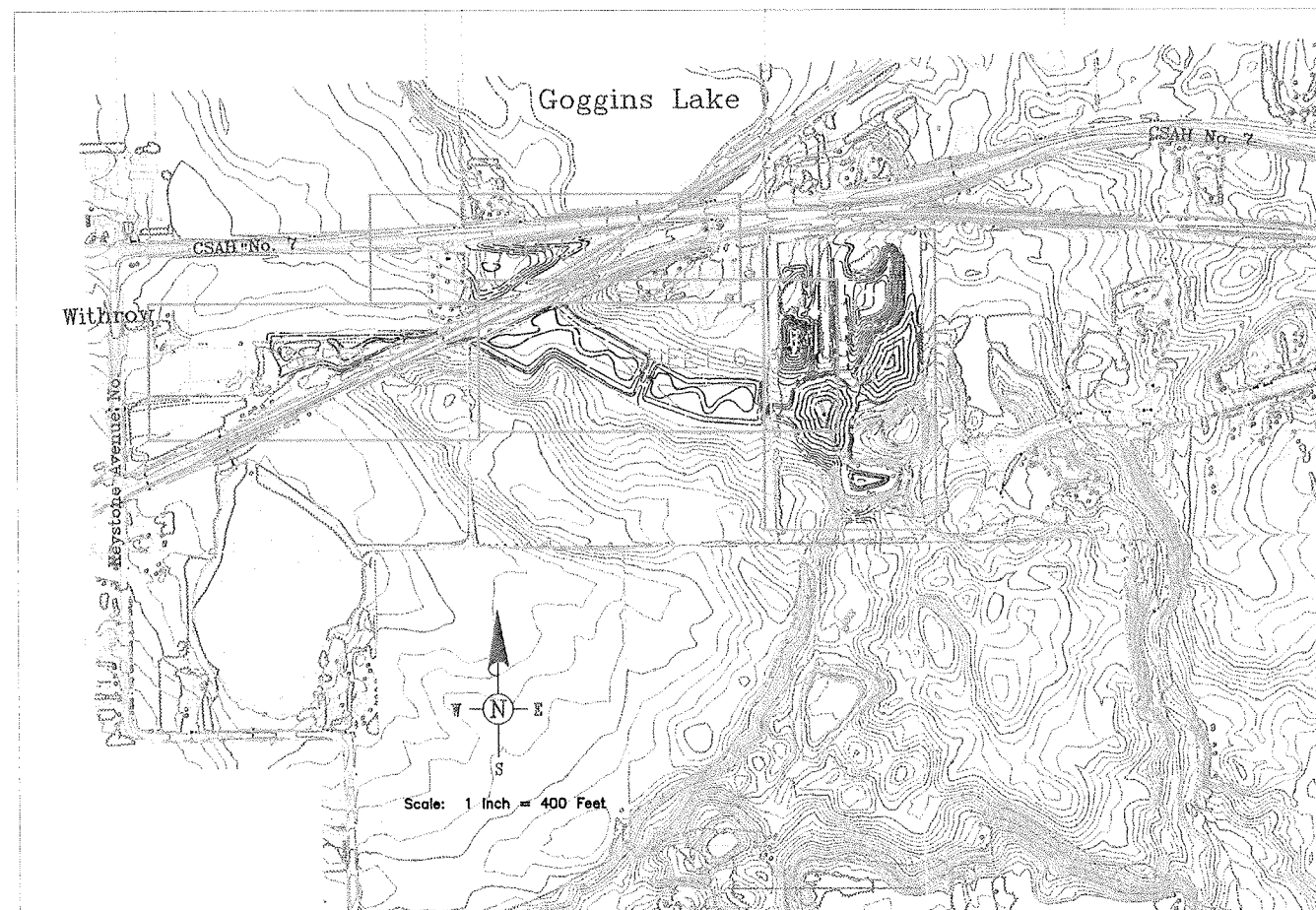
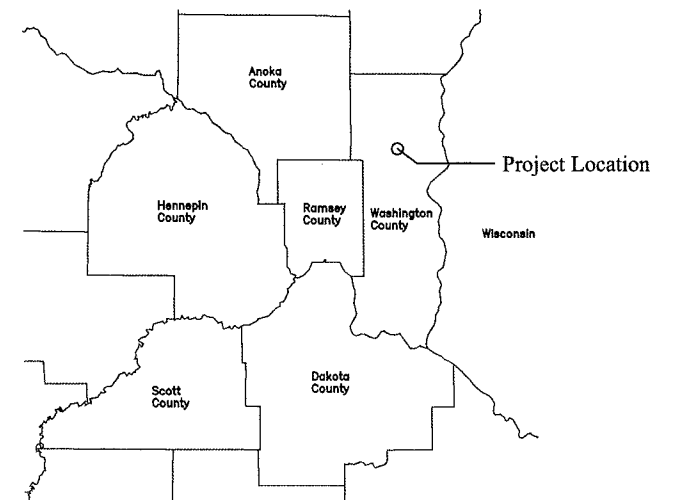

VICINITY MAP

SHEET INDEX

SHEET	TITLE
1	LOCATION MAP & SHEET INDEX
2	BID TAB
3	DETAILS
4	GRADING & STORM SEWER PLAN & PROFILE NO. 1
5	GRADING & STORM SEWER PLAN & PROFILE NO. 2
6	GRADING & STORM SEWER PLAN & PROFILE NO. 3
7	GRADING & STORM SEWER PLAN & PROFILE NO. 4
8	SEEDING & EROSION CONTROL PLAN NO. 1
9	SEEDING & EROSION CONTROL PLAN NO. 2



EMMONS & OLIVIER RESOURCES
3825 LAKE ELMO AVENUE NORTH
LAKE ELMO, MINNESOTA, 55042
(651) 770-8448

I hereby certify that this plan was prepared by me or under my direct supervision and that I am a duly Registered Professional Engineer under the laws of the state of Minnesota.

Date: _____ Reg. No. _____

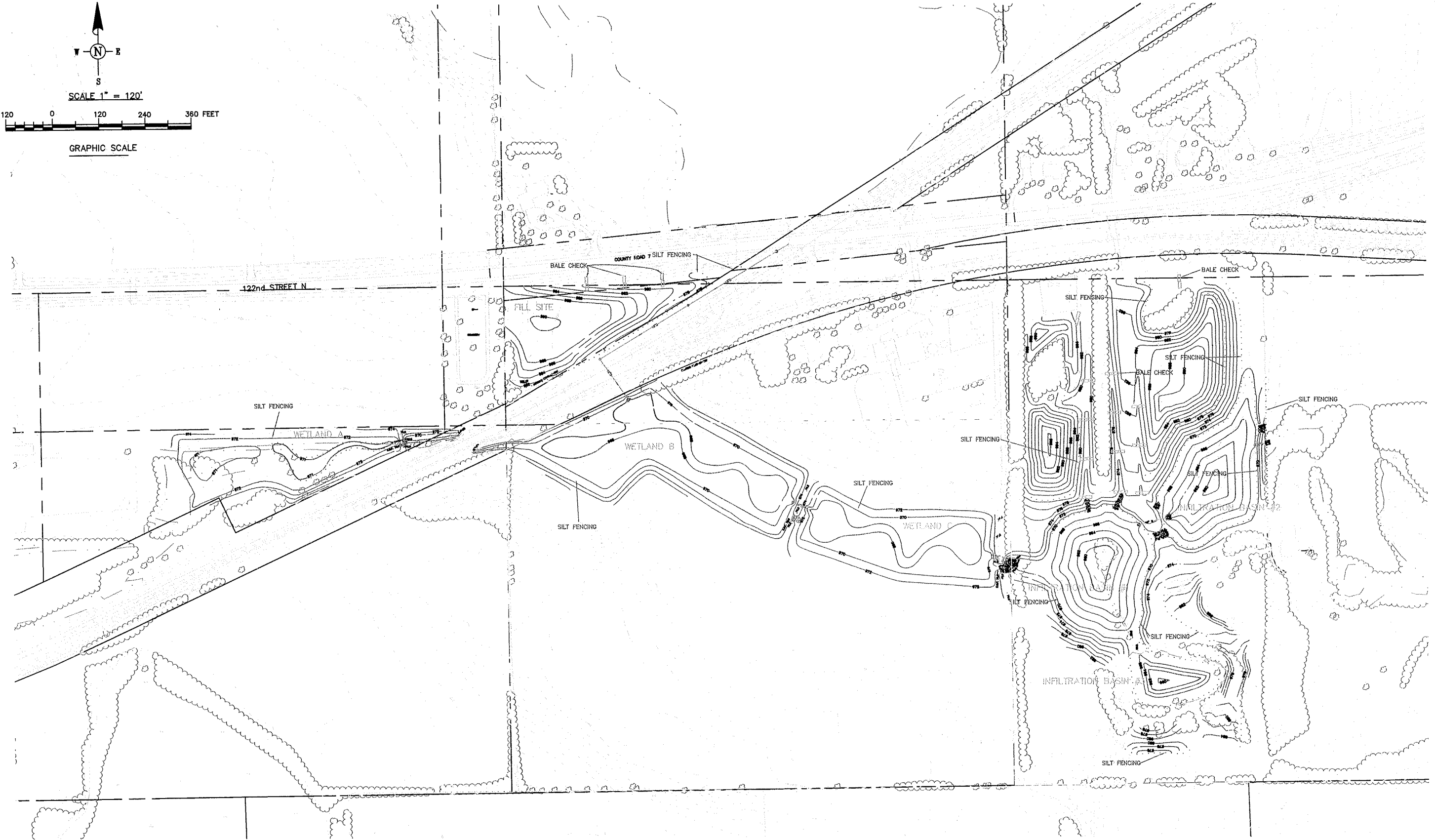
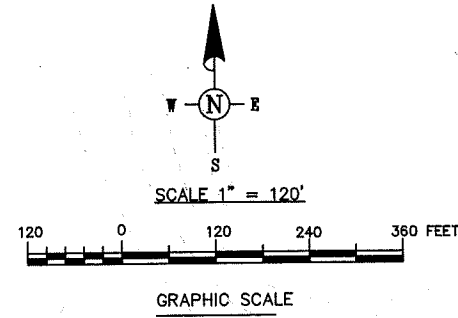

LEGEND:

- EASEMENT
- - - EXISTING CONTOURS
- - - PROPOSED CONTOURS
- - - PROPOSED STORM SEWER
- LCMR
- BWSR
- BALE CHECK
- PROPOSED SILT FENCING

I hereby certify that this plan was prepared by me or under my direct supervision and that I am a duly Registered Professional Engineer under the laws of the state of Minnesota.

Date: _____ Reg. No. _____



EMMONS & OLIVER RESOURCES
 3825 LAKE ELMO AVENUE NORTH
 LAKE ELMO, MINNESOTA, 55042
 (651) 770-8448

BROWNS CREEK WATERSHED DISTRICT TROUT HABITAT PRESERVATION PROJECT		PROJECT NUMBER: 98100-1
LOCATION OF LCMR & BWSR CONSTRUCTION FUNDS		DWG. FILE NUMBER: THPP-CNF
		DATE: 11/12/99
		SHEET 1 OF 1

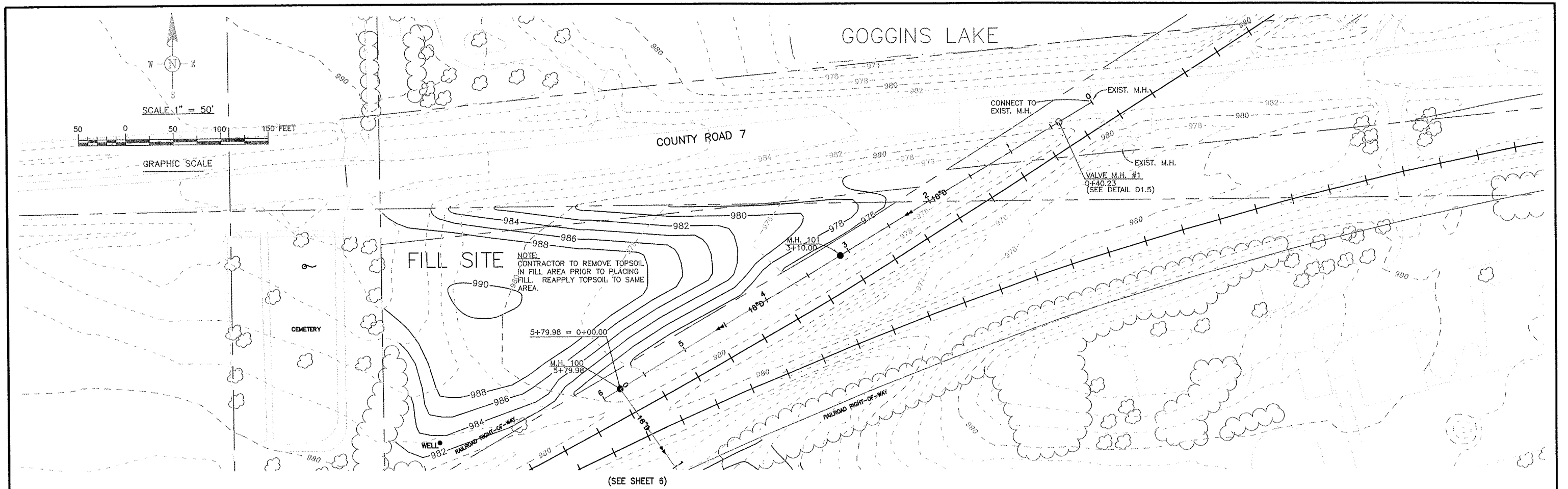

GOGGINS LAKE OUTLET

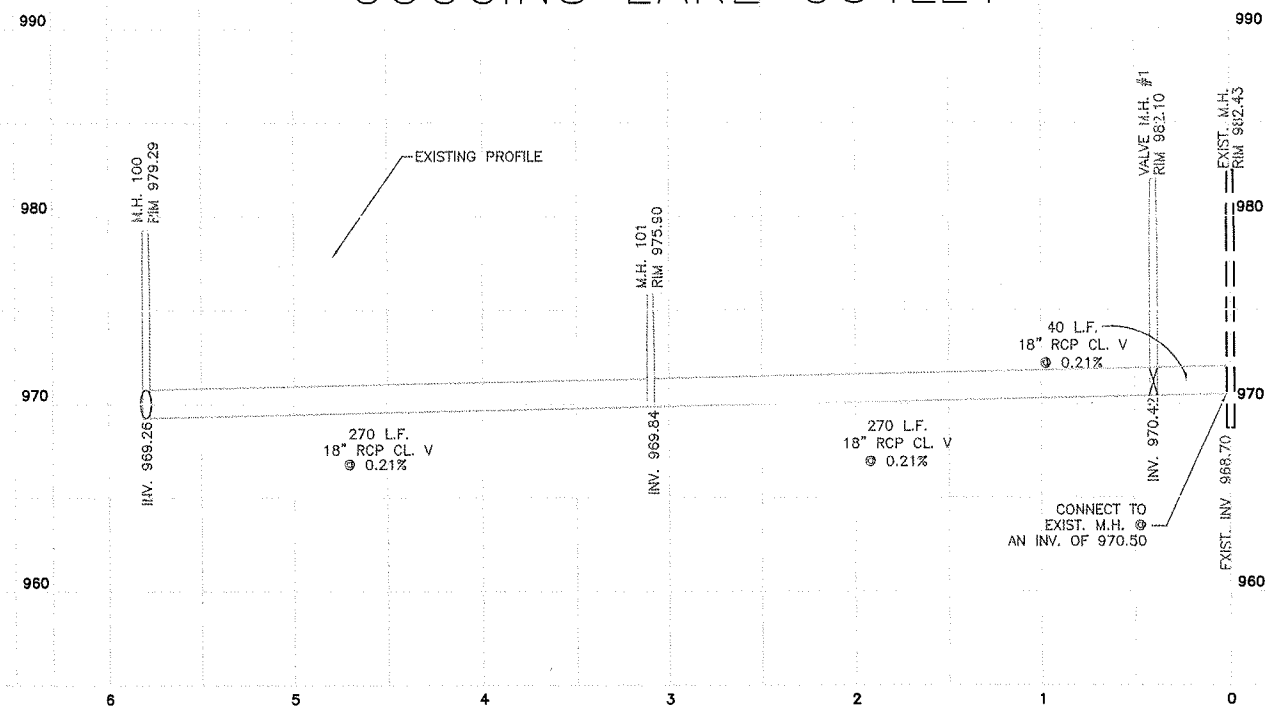

LEGEND

- EXISTING GAS MAIN
- EXISTING STORM DRAINAGE W/ M.H. & F.E.S.
- PROPOSED STORM DRAINAGE W/ M.H. & F.E.S.
- EXISTING CONTOUR
- PROPOSED CONTOUR
- PROPOSED SPOT ELEVATION

I hereby certify that this plan was prepared by me or under my direct supervision and that I am a duly Registered Professional Engineer under the laws of the state of Minnesota.

Date: _____ Reg. No. _____



EMMONS & OLIVIER RESOURCES
 3825 LAKE ELMO AVENUE NORTH
 LAKE ELMO, MINNESOTA, 55042
 (651) 770-8448

BROWNS CREEK WATERSHED DISTRICT
 TROUT HABITAT PRESERVATION PROJECT

**GRADING & STORM SEWER
 PLAN & PROFILE NO. 1**

PROJECT NUMBER:
98100-1
 DWG. FILE NUMBER:
THPP-PP1
 DATE:
11/11/99

SHEET
4

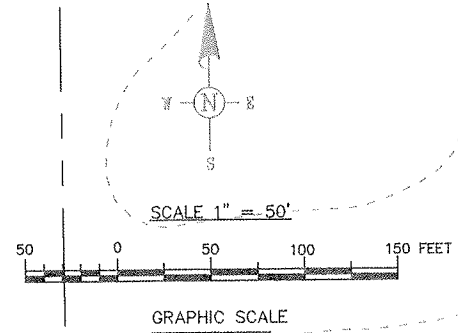

WETLAND A

NOTE:
CONTRACTOR TO SALVAGE TOPSOIL &
REAPPLY TO SAME AREA WHICH TOPSOIL
WAS REMOVED.

NOTE:
CONTRACTOR TO CLEAN OUT
EXIST. 60" RCP CONVEYER

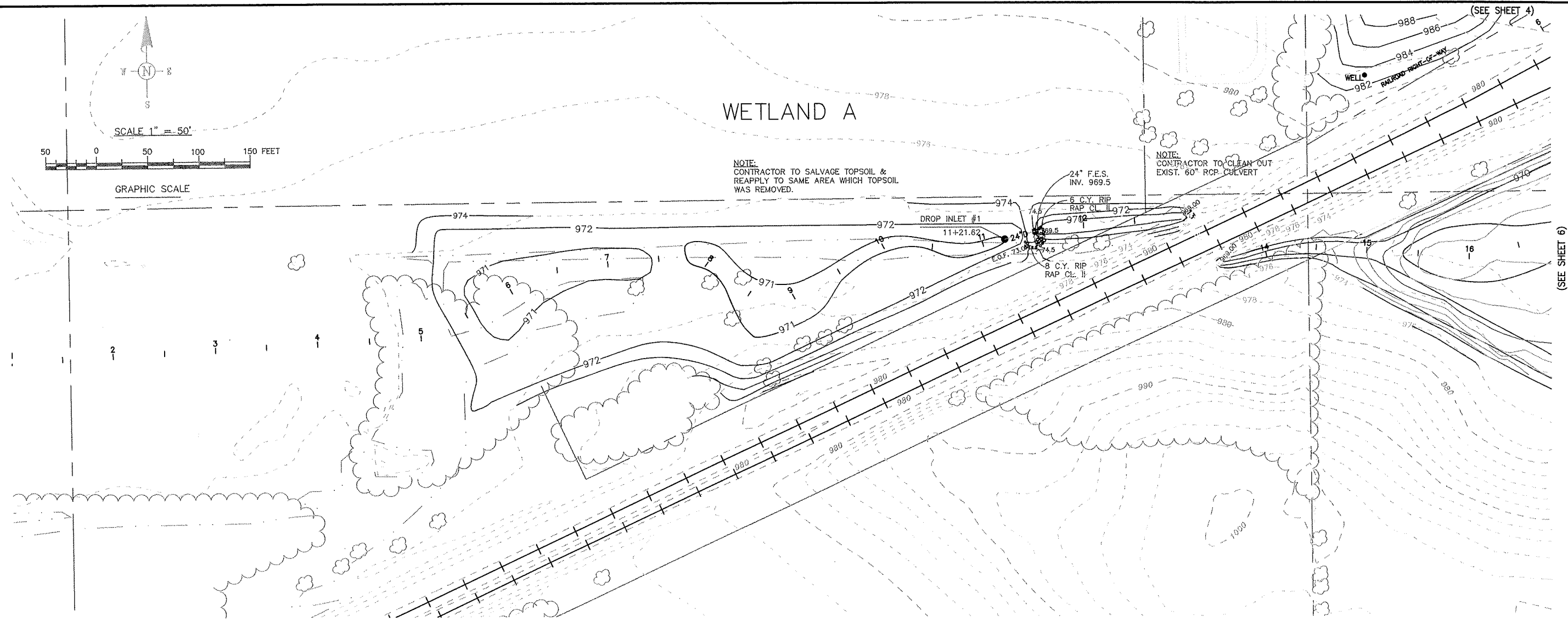

WETLAND A

WETLAND B

PROPOSED PROFILE EXIST. PROFILE

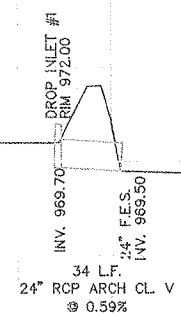

LEGEND

- EXISTING GAS MAIN
- EXISTING STORM DRAINAGE W/ M.H. & F.E.S.
- PROPOSED STORM DRAINAGE W/ M.H. & F.E.S.
- EXISTING CONTOUR
- PROPOSED CONTOUR
- PROPOSED SPOT ELEVATION

I hereby certify that this plan was prepared by me or under my direct supervision and that I am a duly Registered Professional Engineer under the laws of the state of Minnesota.

Date: _____ Reg. No. _____



EMMONS & OLIVIER RESOURCES
3825 LAKE ELMO AVENUE NORTH
LAKE ELMO, MINNESOTA, 55042
(651) 770-8448

BROWNS CREEK WATERSHED DISTRICT
TROUT HABITAT PRESERVATION PROJECT
**GRADING & STORM SEWER
PLAN & PROFILE NO. 2**

PROJECT NUMBER:
98100-1
DWG. FILE NUMBER:
THPP-PP2
DATE:
11/11/99

SHEET
5

(SEE SHEET 6)

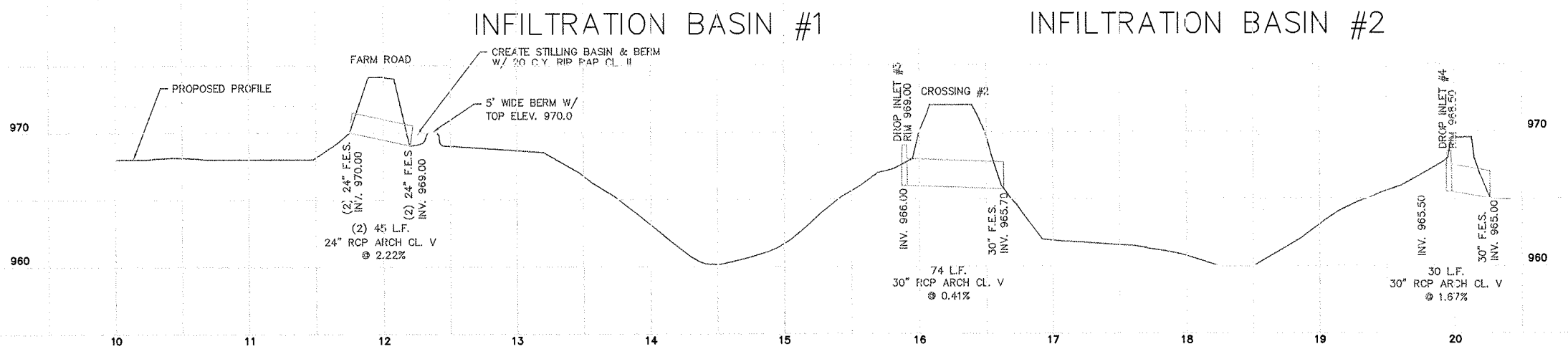
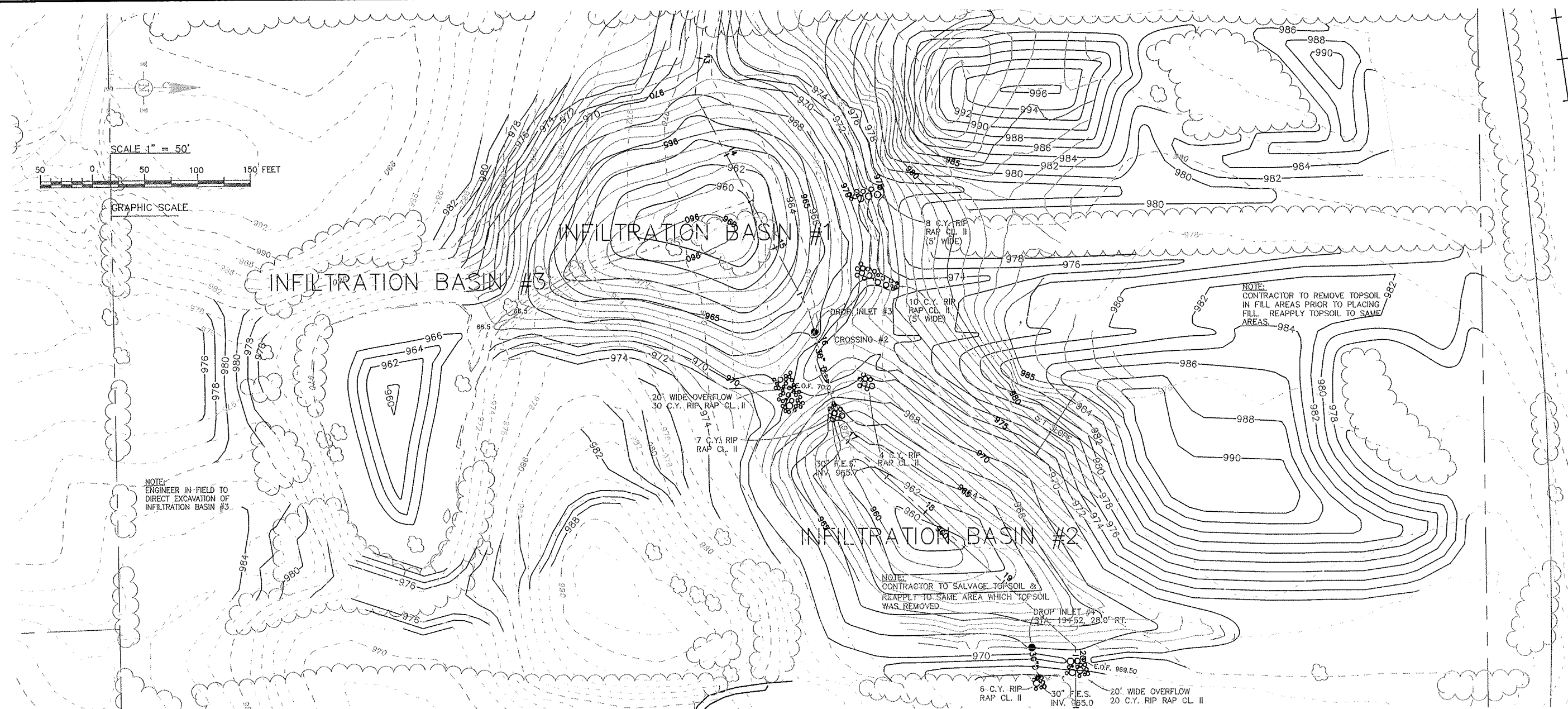
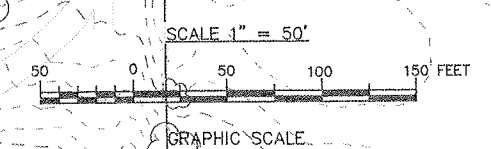

LEGEND

	EXISTING GAS MAIN
	EXISTING STORM DRAINAGE W/ M.H. & F.E.S.
	PROPOSED STORM DRAINAGE W/ M.H. & F.E.S.
	EXISTING CONTOUR
	PROPOSED CONTOUR
	PROPOSED SPOT ELEVATION

I hereby certify that this plan was prepared by me or under my direct supervision and that I am a duly Registered Professional Engineer under the laws of the state of Minnesota.

Date: _____ Reg. No. _____



EMMONS & OLIVIER RESOURCES
 3825 LAKE ELMO AVENUE NORTH
 LAKE ELMO, MINNESOTA, 55042
 (651) 770-8448

BROWNS CREEK WATERSHED DISTRICT TROUT HABITAT PRESERVATION PROJECT	
PROJECT NUMBER: 98100-1	SHEET 7
DWG. FILE NUMBER: THPP-PP4	
DATE: 11/11/99	

Proposed Access Easement – DeWolf Property

The Northerly 30.00 feet of the Easterly 645.00 feet of the Northeast Quarter of Section 2, Township 30 North, Range 21 West, Washington County, Minnesota, together with the Northerly 30.00 feet of the Westerly 80.00 feet of the Northwest Quarter (NW ¼) of Section 1, Township 30 North, Range 21 West, Washington County, Minnesota, together with the Easterly 30.00 feet of the Southerly 600.00 feet of the Southwest Quarter (SW ¼) of Section 31, Township 31 North, Range 20 West, Washington County, Minnesota.

Proposed Description Lueck Easement
Section 31, Township 31 North, Range 20 West, Washington County, Minnesota

That part of the West Half (W 1/2) of the Southwest Quarter (SW 1/4) of the Southeast Quarter (SE 1/4) of Section 31, Township 31 North, Range 20 West, Washington County, Minnesota, described as Commencing at the southwest corner of said Southwest Quarter (SW 1/4) of the Southeast Quarter (SE 1/4) of Section 31; thence North 0 degrees 31 minutes 26 seconds West, assumed bearing, along the west line of said Southwest Quarter (SW 1/4) of the Southeast Quarter (SE 1/4) of Section 31 a distance of 515.78 feet to the point of beginning of the parcel to be described; thence South 77 degrees 18 minutes 40 seconds East a distance of 232.53 feet; thence South 13 degrees 04 minutes 29 seconds East a distance of 298.87 feet; thence South 9 degrees 23 minutes 18 seconds West a distance of 172.52 feet to the south line of said Southwest Quarter (SW 1/4) of the Southeast Quarter (SE 1/4) of Section 31; thence North 89 degrees 15 minutes 59 seconds East along the south line of said Southwest Quarter (SW 1/4) of the Southeast Quarter (SE 1/4) of Section 31 distance of 50.79 feet; thence North 9 degrees 23 minutes 18 seconds East a distance of 173.54 feet; thence North 88 degrees 10 minutes 00 seconds East a distance of 133.17 feet; thence North 43 degrees 28 minutes 09 seconds East a distance of 152.37 feet; thence North 31 degrees 21 minutes 00 seconds West a distance of 87.59 feet; thence North 81 degrees 44 minutes 50 seconds West a distance of 225.81 feet; thence North 9 degrees 55 minutes 32 seconds West a distance of 141.65 feet; thence North 65 degrees 38 minutes 53 seconds East a distance of 253.26 feet; thence North 49 degrees 05 minutes 45 seconds East a distance of 174.42 feet to the east line of said West Half (W 1/2) of the Southwest Quarter (SW 1/4) of the Southeast Quarter (SE 1/4) of Section 31; thence North 0 degrees 34 minutes 48 seconds West along said east line of the West Half (W 1/2) of the Southwest Quarter (SW 1/4) of the Southeast Quarter (SE 1/4) of Section 31 a distance of 155.04 feet; thence South 40 degrees 57 minutes 49 seconds West a distance of 253.25 feet; thence South 67 degrees 37 minutes 25 seconds West a distance of 172.66 feet; thence South 84 degrees 11 minutes 49 seconds West a distance of 327.83 feet to the west line of said Southwest Quarter (SW 1/4) of the Southeast Quarter (SE 1/4) of Section 31; thence South 0 degrees 31 minutes 26 seconds East a distance of 104.61 feet to the point of beginning.

Proposed Description DeWolf Easement(Constructed Wetland Area)
Section 31, Township 31 North, Range 20 West, Washington County, Minnesota

That part of the Southeast Quarter (SE¹/₄) of the Southwest Quarter(SW¹/₄) of Section 31, Township 31 North, Range 20 West, Washington County, Minnesota, described as commencing at the southeast corner of said Southwest Quarter of Section 31; thence North 0 degrees 31 minutes 26 seconds West, assumed bearing, along the east line of said Southwest Quarter of Section 31, a distance of 504.59 feet to the point of beginning of the parcel to be described; thence continuing North 0 degrees 31 minutes 26 seconds West a distance of 207.23 feet; thence North 86 degrees 0 minutes 45 seconds West a distance of 157.95 feet; thence South 88 degrees 58 minutes 34 seconds West a distance of 199.54 feet; thence North 61 degrees 11 minutes 54 seconds West a distance of 525.02 feet; thence North 50 degrees 22 minutes 36 seconds West a distance of 132.09 feet; thence South 65 degrees 48 minutes 55 seconds West a distance of 81.95 feet; thence South 64 degrees 35 minutes 31 seconds West a distance of 159.09 feet; thence South 64 degrees 51 minutes 45 seconds West a distance of 131.13 feet; thence South 64 degrees 47 minutes 05 seconds West a distance of 61.30 feet; thence South 0 degrees 31 minutes 32 seconds East a distance of 3.39 feet; thence South 61 degrees 35 minutes 24 seconds East a distance of 297.92 feet; thence North 50 degrees 0 minutes 53 seconds East a distance of 139.21 feet; thence South 60 degrees 40 minutes 35 seconds East a distance of 358.14 feet; thence South 70 degrees 49 minutes 19 seconds East a distance of 354.08 feet; thence South 86 degrees 0 minutes 43 seconds East a distance of 298.72 feet to the point of beginning. This parcel contains 261230 Square feet/6.00 Acres.